

Thank you for purchasing Gejigeji club's product. "KEYER XR" is a CW Message Keyer for ham radio. In order to understand the function and performance of KEYER XR, please read the whole of this manual. Please keep this manual. If anything to reconfirm occurs later, please read again

Restrictions on product use

This product is designed in consideration of safety. Nevertheless, electronic devices in general can malfunction or fail due to wrong usage. It is the responsibility of the buyer, when using our products, to observe the optimum usage, and to avoid situations bodily injury, loss of human life or damage to property.

Our products are manufactured on the assumption that people with the knowledge of ham radio. So the explanation about electronics required for ham radio and how to communication etc. is omitted in this manual.

Please observe the law of each country about the operation rule of ham radio.

Gejigeji club is continually working to improve the quality of its product. The information contained herein subject to change without notice.

Connection to transceiver

Keying Output (KEY OUT)

3.5mmφ Stereo Plug
KEY OUT is connected to a keying input of transceiver. Also EXT PTT can be connected to a linear amplifier or a pre-amplifier.

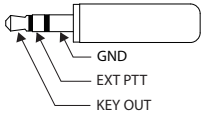

Paddle Input (PADDLE)

3.5mmφ Stereo Plug
Connect the paddle. Press F1 and F2 at the same time to reverse the paddle left and right.

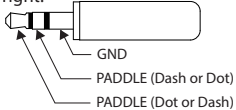

External Speaker (EXT SP)

3.5mmφ Monoral Plug
Connect to an external speaker or earphone. When connected, the built-in speaker will be disconnected. Also, the output is OTL output, so if either one of the terminals is connected to ground, it will not be output normally.

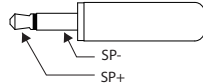

Straight key input (STRAIGHT)

3.5mmφ Monoral Plug
Connect Straight key.

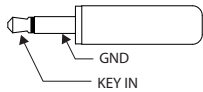

Troubleshooting

No sound comes out of the speaker

Side tone may be turned off. Press F1 and F4 at the same time to turn on the side tone. Is the front volume control set to the minimum?

Operation is unstable

If the dry batteries run out and the combined voltage of the two drops to about 2V, operation will become unstable. Replace the batteries with new ones.

Does not work properly

On rare occasions, the value of the internal memory may become incorrect if it is operated with a low battery voltage. After replacing the battery with a new one, turn on the power while pressing all of F1, F2, F3, and F4 to perform initialization.

"OK" does not occur after turning on the power
Turn off the power, wait at least 10 seconds, and then turn it on again. When no operation is performed, the standby mode is set and the current consumption is 10 μA or less. Therefore, the internal voltage is not discharged immediately. Or, press any function button to discharge and then turn on the power.

Function of each part

Power Switch (POWER)

Tilt to the right, then power will be turned on.

Function switch

The various function can be controlled by 4 function switches.

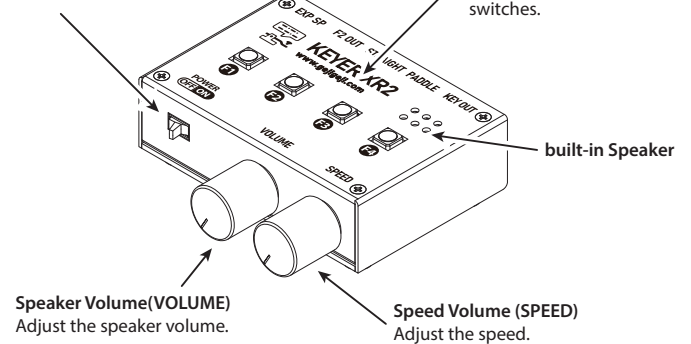

Speaker Volume (VOLUME)
Adjust the speaker volume.

Speed Volume (SPEED)
Adjust the speed.

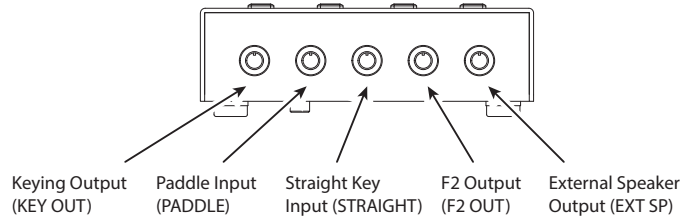

Battery Attachment

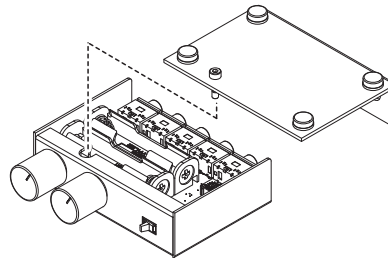

1. Loosen the knob screw on the bottom.
Since the knob screw is a captive screw, it cannot be removed from the bottom cover.
2. Slide the bottom cover and remove it.
3. Install the battery according to the polarity of the battery case.
4. Attach the bottom cover.
5. Tighten the knob screw on the bottom.

CW Tone over voice (F2)

CW tone over voice is so called "F2" or "F2A" in Japan. CW tone is modulated into a voice carrier and this is mainly used above 2.4GHz FM operation. This keyer provides the PTT signal and the CW tone signal output to support this F2 mode.

F2 Output (F2 OUT) 3.5mmφ Stereo Plug
CW tone and PTT signal is output.

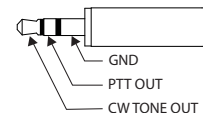

Example of connection to a transmitter (Handheld)

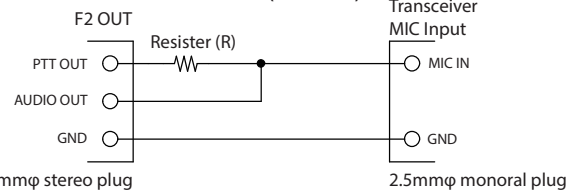

Resister value

Standard 2.2kΩ, ICOM 33kΩ etc.

For details, please refer to the instruction manual of the transmitter.

Example of connection to a transmitter (Base Station)

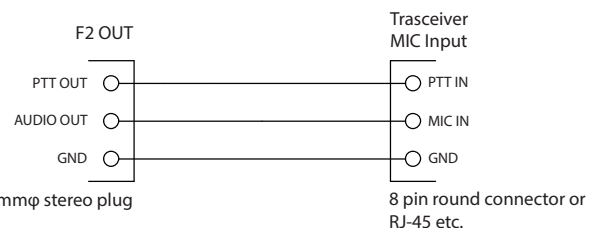

Audio output level adjustment for F2

1. Remove the bottom cover.
2. Adjust the trimmer potentiometer (VR1) next to the battery case. Normally, you can obtain sufficient modulation by turning about 30% from the left.

Paddle/Straight key

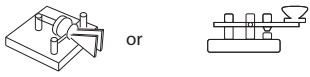

It is equipped with a squeeze function that alternately sends dot and dash when both are pressed simultaneously.

Side Tone ON/OFF

F1 + **F4** "E"

Turn on/off the side tone emitted from the built-in speaker.

Reverse paddle

F1 + **F2** "R"

The left and right of the paddle are reversed.

Message playback

F1 ~ **F4** Select a channel to play

If you press any of the F1 to F4 buttons, or operate the paddle or straight key, playback will immediately stop. It also stops automatically when the message is finished.

Repeat playback

F1 ~ **F4** Press for over 1 second

Volume adjustment



Turn the front volume to the right to increase the speaker volume. If you connect an external speaker to the external speaker output, no sound will be output from the built-in speaker.

Speed adjustment



The speed will be faster as you turn the speed volume on the front to the right. It can be changed in the range of about 5 WPM to 40 WPM. The variable range can be changed in the detailed settings.

Delay output

F2 + **F3** Sync mode "SYNC"
Delay mode "DLY"

It is possible to switch the delay output setting of KEY output. If you want to control the PTT timing for an external linear amplifier or pre-amplifier, set it to delay mode. Synchronous mode is usually fine.

Tune function

F1 + **F3** → **F1** ~ **F4**
Stop by pressing any

Puts the keyer in the continuous keying state. It is used when continuous carrier transmission is required due to adjustment of radio equipment.

Message recording

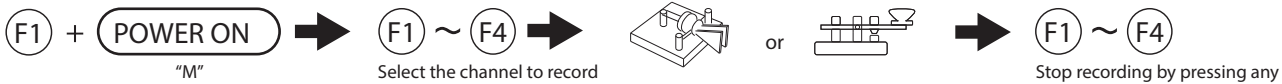

Various detailed settings

Number of repeats/interval

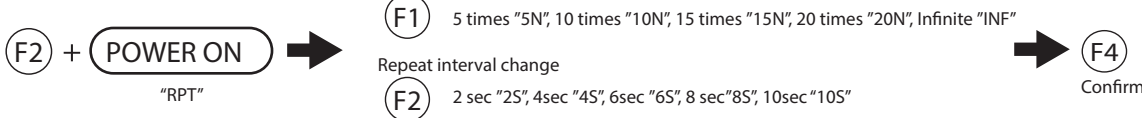

Sidetone frequency

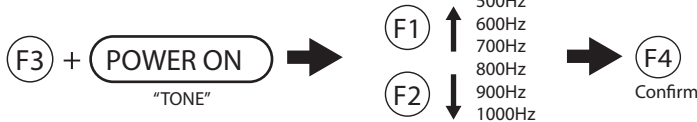

Speed range change

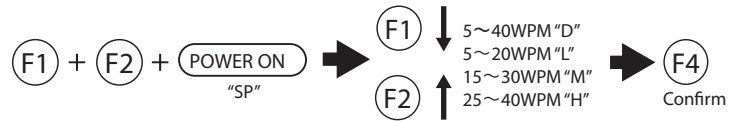

Squeeze timing



Dot Dash Ratio

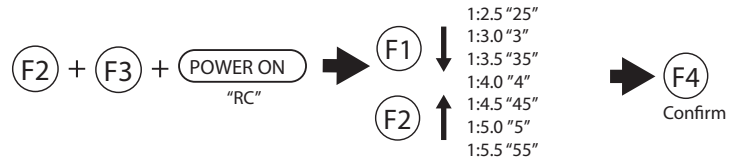

Squeeze timing

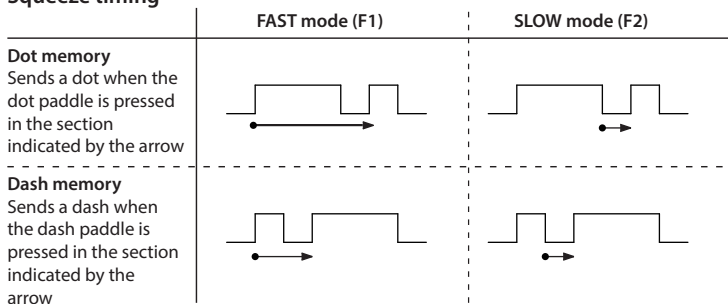

The length of messages that can be recorded

When recording with a paddle
Up to 65,532 can be recorded per channel. Record the following four types of status and count each as one.
1. Dash 2. Dot 3. Space between letters 4. Space between words
For example, "AB C" uses 12 pieces.
A . - . 2 + 1 (Letter space between A and B)
B - . . . 4 + 1 (Word space between B and C)
C - . - . 4

When recording with a straight key
Up to 16,383 can be recorded per channel. Alternately record the following two types of length and count each as one.
1. Keying 2. Space
For example, "AB C" uses 19 pieces.
A . - . 3 + 1 (Letter space between A and B)
B - . . . 7 + 1 (Word space between B and C)
C - . - . 7

Synchronous mode timing chart(SYNC)

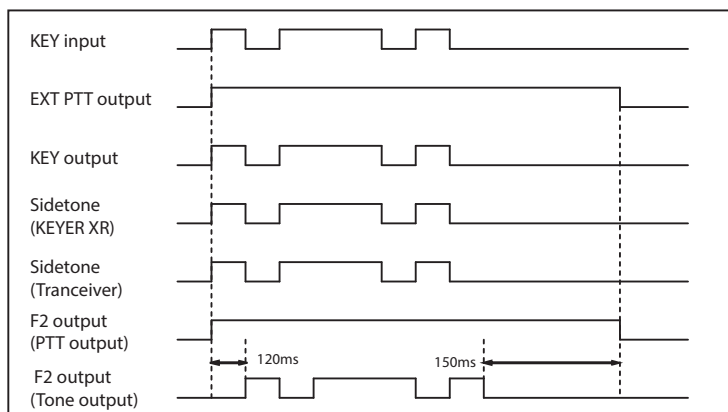

Delay mode timing chart(DLY)

